

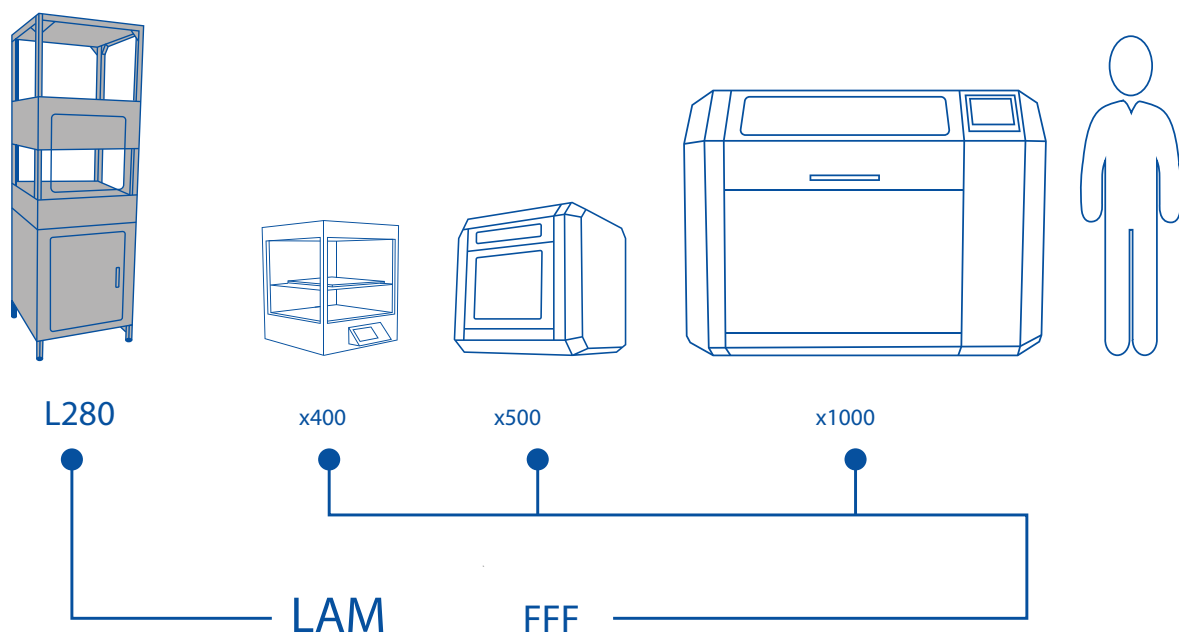

German RepRap
L280 3D printer

Liquid Additive Manufacturing (LAM)

Liquid additive manufacturing (LAM) is an additive manufacturing process in which liquids (or low-strength materials) can be additively processed, such as liquid silicone rubber (LSR). The technical characteristics of the LAM printed objects and the injection molding process are almost identical. Further advantages include high process speeds and distortion-free 3D printing of any component.



CONTENT

New Possibilities	2
Design Freedom	3
Application	4
Maintenance & Service	10
Technical Specifications	11

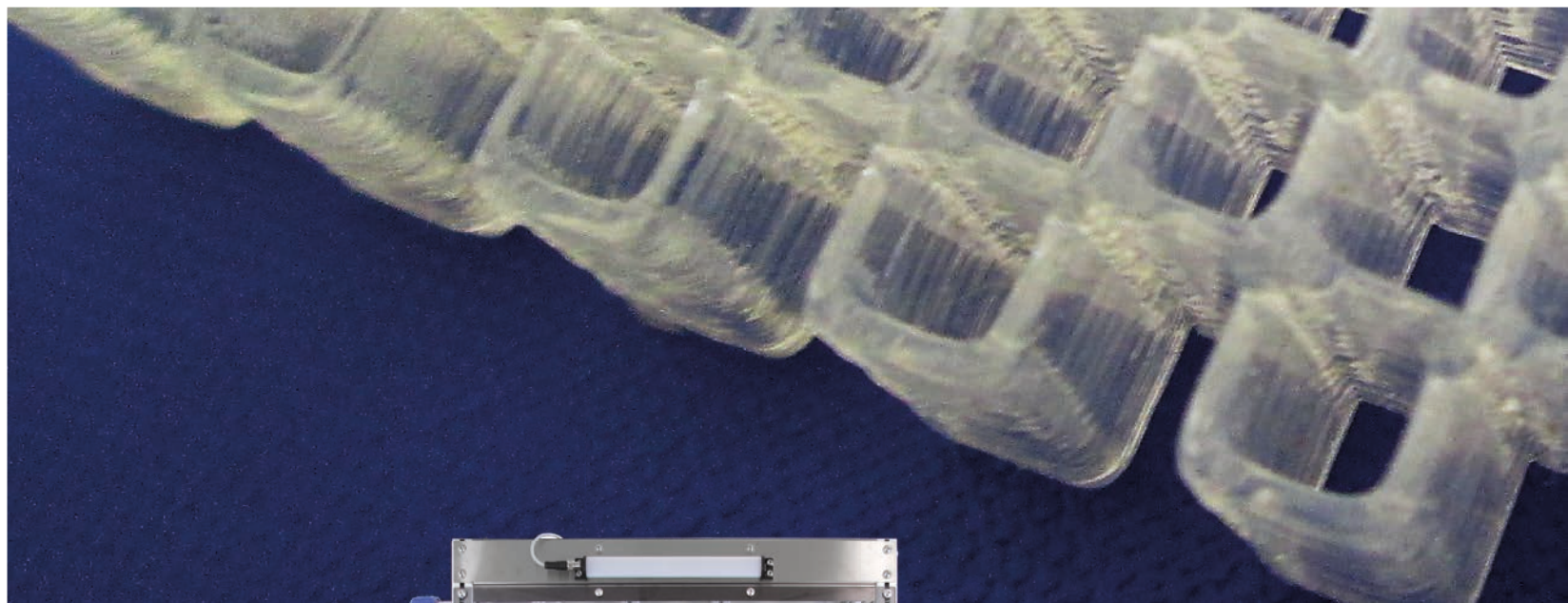

INDUSTRIE
PREIS 2018
QUALIFIZIERT



Liquid Additive Manufacturing

Discover new possibilities

With the Liquid Additive Manufacturing (LAM) 3D printer from German RepRap a true „Game Changer“ enters the market. For the first time it is possible use liquid material such as liquid silicone rubber (LSR) for additive manufacturing. The same material is already used for many products and different applications. This brings new possibilities in terms of shapes and geometries, which are not processable with other traditional manufacturing methods. Bionic shapes or other complex objects can be manufactured, in quantities of 1 as well as in mass production - with almost identical and sometimes even better properties compared to injection molding. The build platform of the L280 is suitable for the printing of small and large objects, as well as for small series.

Your advantages at a glance

- ✓ Use of a material that is already used in conventional production processes - almost identical material properties, that customers already know
- ✓ Enormous time and cost savings, faster production compared to traditional manufacturing technologies
- ✓ Prototypes serve as fully functional initial samples and, after certification, can speed up the following process of high-volume production
- ✓ Very high process stability and stand-alone printing



New possibilities in terms of geometry and shape

The Liquid Additive Manufacturing technology enables new possibilities in terms of geometries and shapes, that are normally very difficult or even impossible to process with conventional production methods

With the LAM 3D printing technology, the application of the material can be precisely controlled. Thus, cross, lattice or honeycomb structures are not a problem, the structure in the object can be applied according to their own ideas and the respective application. This in turn leads to other technical characteristics. Where conventional production processes such as injection molding require all molecules to be aligned, LAM technology can be used to influence the application direction and, thus, the cross-linking at the macro molecular level, resulting in better material strength compared to injection molding.

Business is already rethinking processes. For the first time it is now possible to apply liquid or soft materials such as silicone in a free form, on almost all surfaces. This brings unique innovative possibilities to the world.

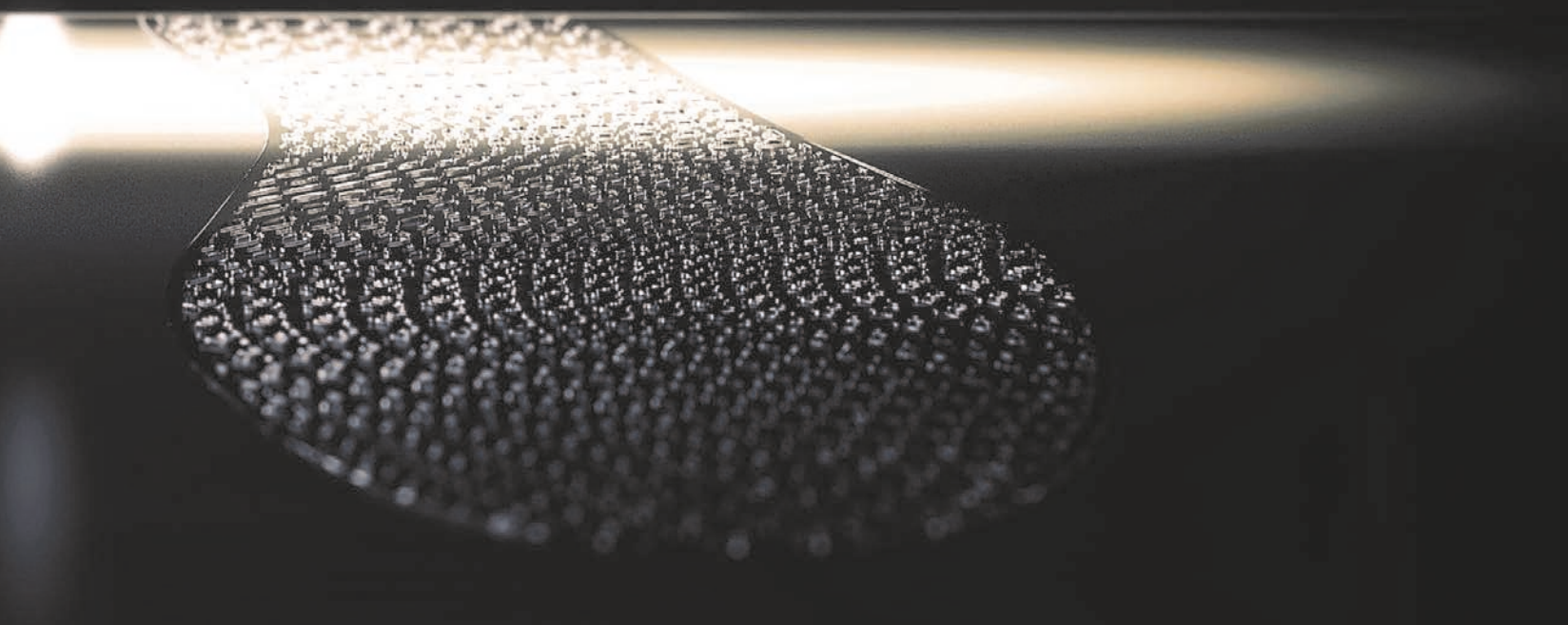

Material - EVOLV3D from DOW

Liquid Silicone Rubber (LSR) from DOW is already being used in many companies for a wide range of products

As the name implies, it is a liquid silicone. An important point should be clarified in advance: It is a real silicone, an LSR, which is thermally cross-linking. The material does not contain any acrylic hardener, does not become UV-crosslinked and is almost identical to injection molding in all properties. Especially for products that require a high degree of fineness, the material is a big advantage. Companies already using this silicone can now combine the unique benefits of already used silicone with faster prototyping and small batch production of highly complex parts. The variation of different infill options of the same material, results in a wide range of possibilities, for example, for different damping properties. Depending on the mixing ratio, flexible products or even rigid printing results can be produced. This brings a decisive new possibility - away from the pure prototype process, individual parts can now be produced, in unit number 1, but with the technical requirements of injection molding quality.

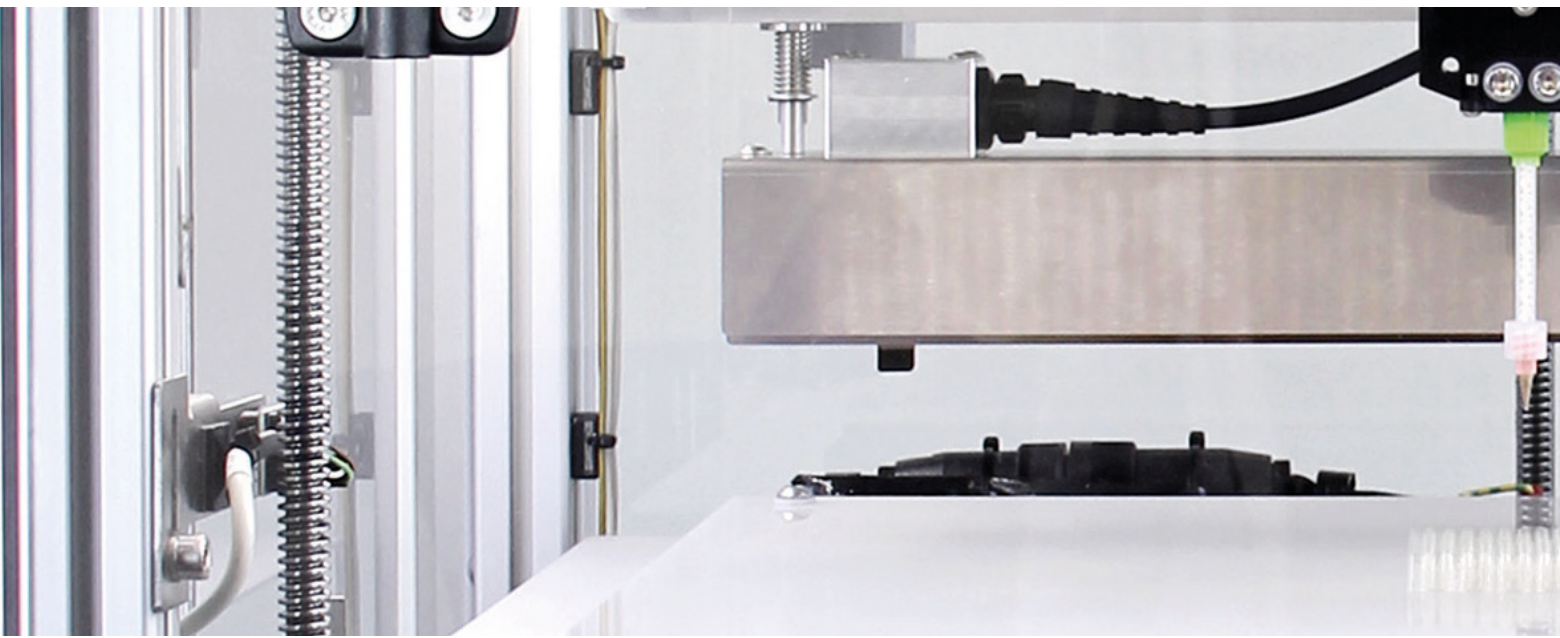

Application and Branches

Silicones are indispensable in many industries. From the soother to the Computer keyboard – these plastics are used for a wide variety of products. They are mainly used in the construction, automotive and electrical & electronics industries, as well as in medical technology, cosmetics, textiles and paper. Demand is fairly balanced across several large industries. The construction industry needs silicones for sealants, adhesives and coatings. The electronics industry mainly uses silicones to protect electronic components from extreme heat, moisture, salt, corrosion and dirt. Silicones are included in computers, telephones, and LED lights, and their capabilities are being gradually expanded.



Automotive



Aerospace



Medicine



Electronics



Food Industry



Prototyping



Research



Tool and Mold Making

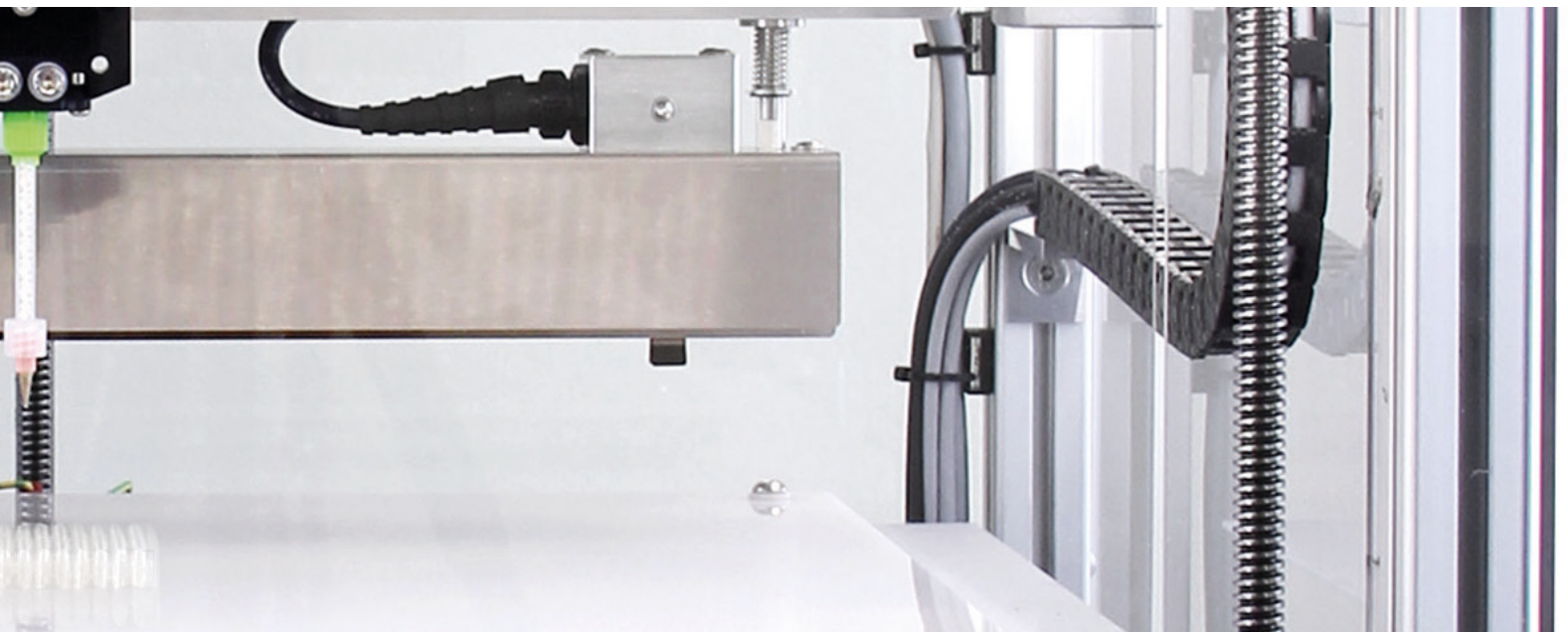

Thermal Cross-linking

The special halogen lamp releases activation energy to accelerate the complete cross-linking, on a molecular level, between the two components. A finely tuned action, for both small and large objects, is ensured by the travel speed of the lamp. Due to this thermal cross-linking, the printing time is considerably reduced, at the same time the printing result, especially in terms of time savings, sets new standards.

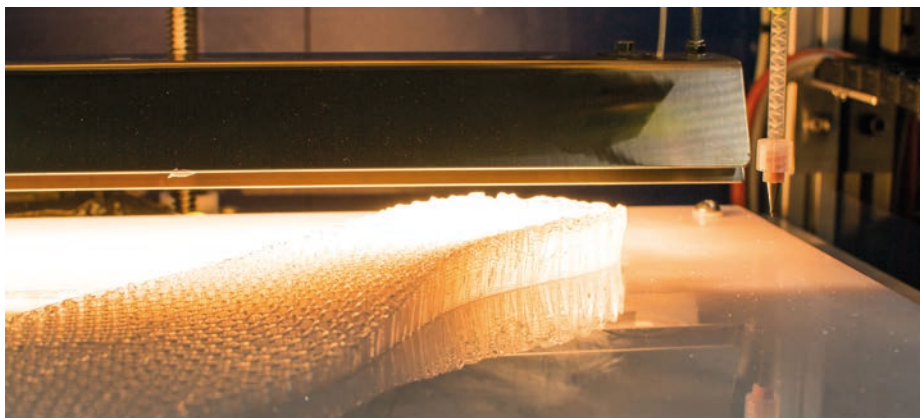

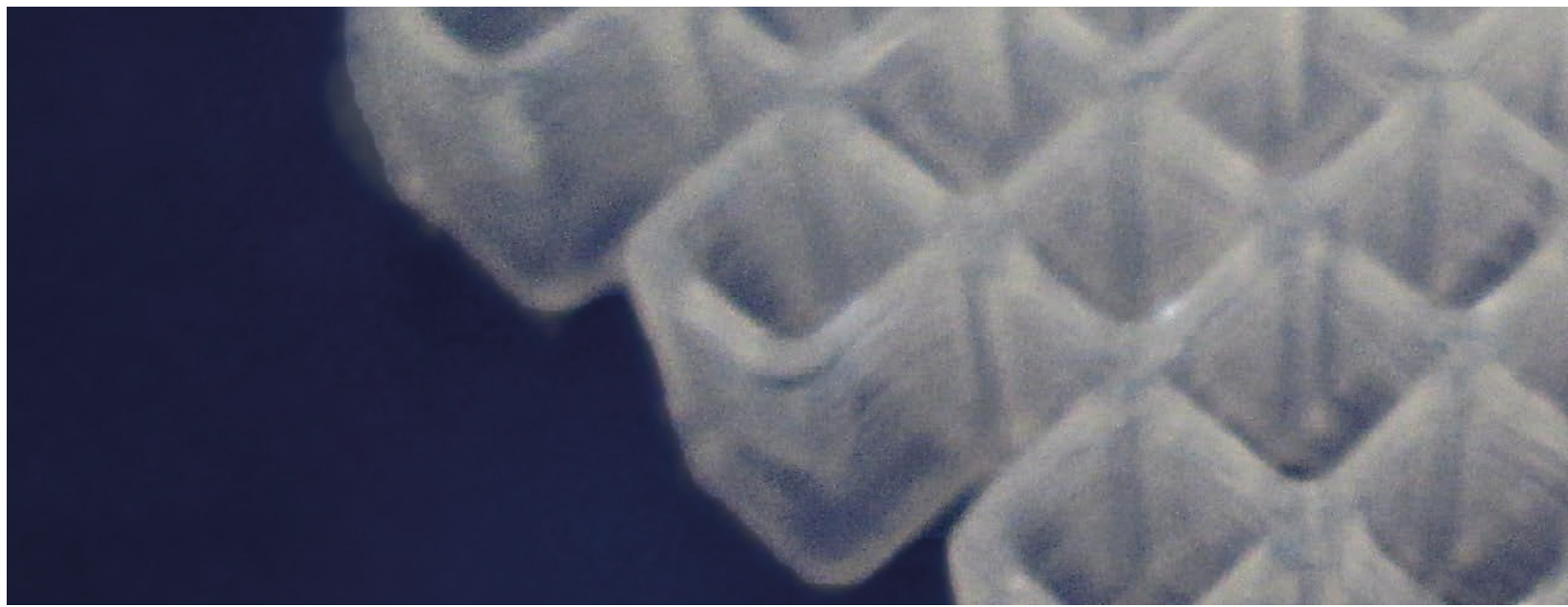

Variable Nozzles

By using different nozzles, both fine and larger objects can be processed in a short printing time. Depending on the application, different dosing nozzles can be used. Due to a Luer system the nozzles are easy to exchange at any time.

Material Feed

The material supply comes with a cartridge system or optionally with material pails. When using cartridges, the pressure is automatically adjusted by an upstream pressure regulator.



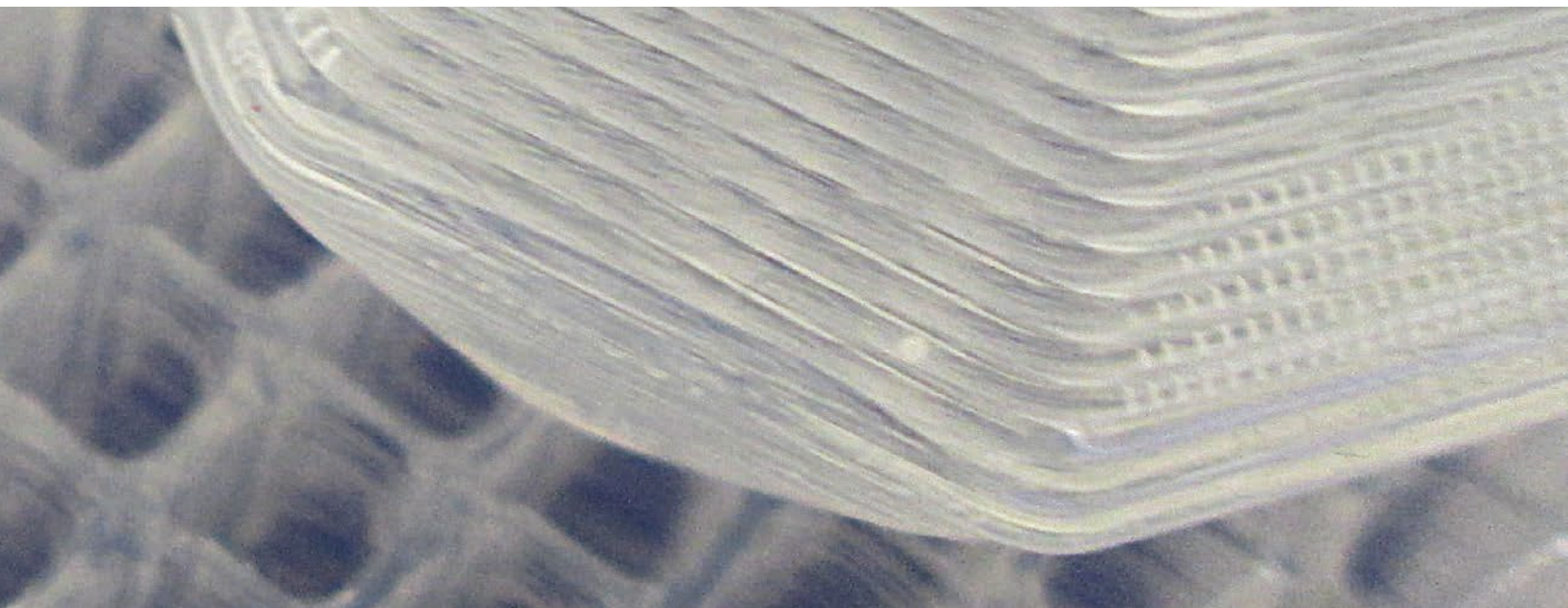

Safety

The sound safety technology monitors the curing process. Deviations are registered and displayed by the system. Through an integrated special light system the statuses of the safety electronics are displayed for the customer. Any Irregularities will automatically stop the print job.





Heated Print Bed

To support the fine-tuning and the optimal curing of the material, the L280 works with a heated print bed. This allows not only a good layer adhesion but also ideal stability in the Adjustment of the printing plate.





Maintenance and Service

Tailored to the needs of industrial use, the customer is optionally offered a maintenance contract as well as professional on-site service by a trained technician. The worldwide German RepRap partner network ensures a reliable service through a personal contact person.

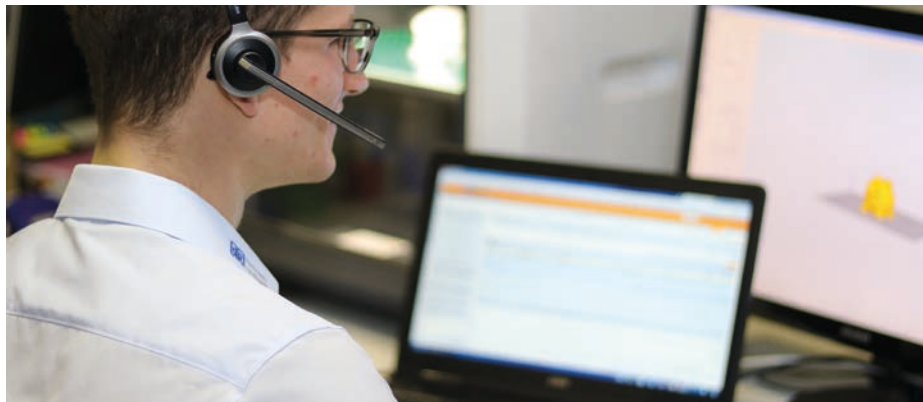

Specifications

Build platform* (XxYxZ)	280 x 280 x 200 mm
Print speed	10 - 150 mm/s
Travel speed	10 - 300 mm/s
Position accuracy* (X/Y)	+/- 0,5 mm
Layer height (min.)	0,22 - 0,9 mm
Material	EVOLV3D™ LC 3335 Liquid Silicone Rubber (LSR)
Nozzle options	0,23 0,4 0,8 mm
Print bed temperatur	110°C
Options	Maintenance contract, material pails
File transfer	USB, Stand-alone printing with touch display, ethernet
Software	Simplify3D Software
Operating voltage	230 VAC
Ambient temperature	15-26°C
Outer dimensions (WxDxH)	Printer with cartridge system: 700 x 700 x 2040 mm Printer with material pails: 700 x 700 x 2260 mm
Weight	120 kg (without material removal system)
Technology	LAM (Liquid Additive Manufacturing) Build platform* (XxYxZ)

* Variances are possible depending on options/materials

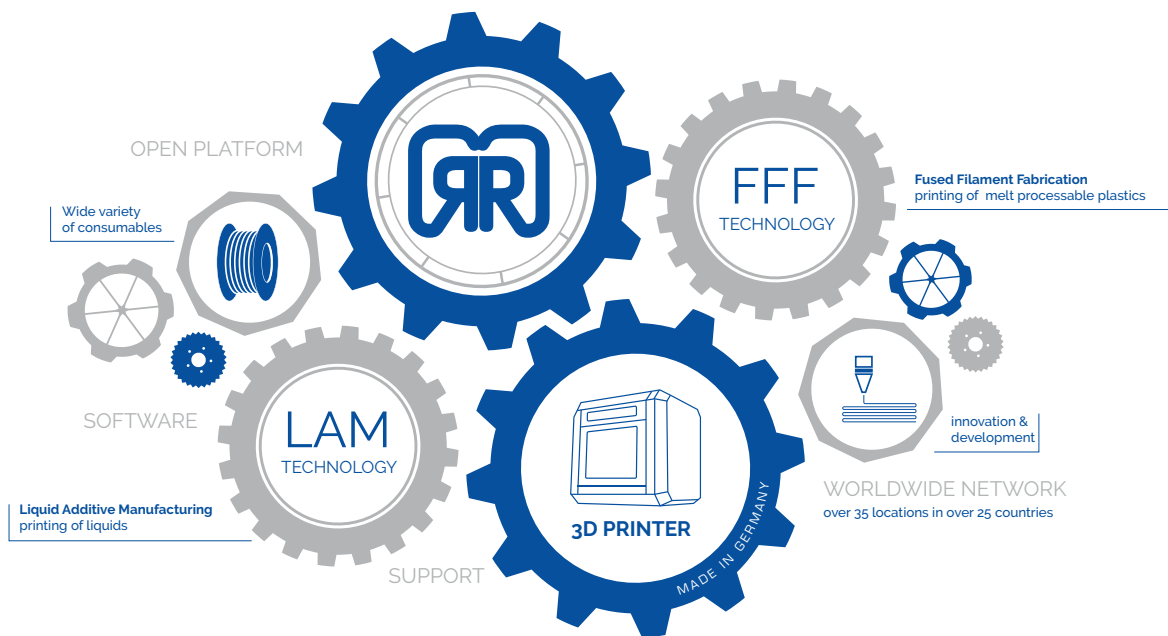

What makes us different?

- ✓ Largest German manufacturer of FFF 3D printers with enclosed print area
- ✓ Global leader in new 3D printing technologies, including LAM technology
- ✓ Variety of services, including training and sample printing
- ✓ Further development tailored to customer requirements, cooperative product development
- ✓ Open material platform, no closed system
- ✓ Wide variety of materials and products

German RepRap GmbH

Kapellenstr. 7
85622 Feldkirchen
Germany

+49 (0)89 2488986-0
info@germanreprap.com
www.germanreprap.com